

ACCESSORIES

BATTERY LIFTING DEVICES

MODEL BLB-6000

Battery Lifting Beams provide a convenient way to handle batteries.

Lifting Beams

BHS Beams are made of hardwood construction, yet are light enough for one-person operation. The Lifting Beams have natural spark-proof insulation and safety rubber hook retainers. Optional hooks available.

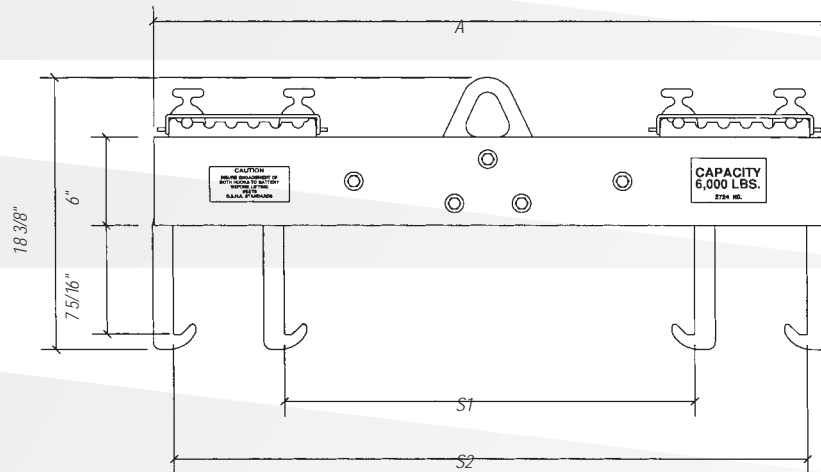
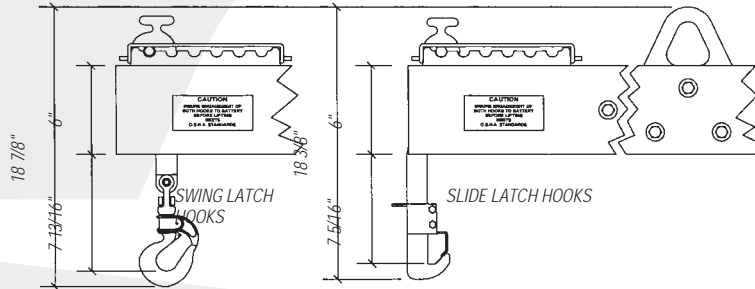

BATTERY LIFTING DEVICES

Model	Capacity	Clear Span (S1 - S2)	Length (A)	Weight
BLB-6000 (Battery Lifting Beam)	6,000 lbs.	27 1/2" - 42 1/2"	45"	58 lbs.
BLB-6000-48 (Lifting Beam-48", 52" Oal)	6,000 lbs.	35 1/2" - 50 1/2"	52"	110 lbs.
BLB-6000-LHG (LB w/Load Hog Hooks)	6,000 lbs.	27 1/2" - 42 1/2"	45"	58 lbs.
BLB-SWG-LCH (LB w/Swing Latch Hooks)	6,000 lbs.	27 1/2" - 42 1/2"	45"	58 lbs.
BLB-SLD-LCH (LB w/Slide Latch Hooks)	6,000 lbs.	27 1/2" - 42 1/2"	45"	58 lbs.
BLB-6000-SHG (LB w/Super Hog Hooks)	6,000 lbs.	27 1/2" - 42 1/2"	45"	60 lbs.

## ACCESSORIES

### BATTERY LIFTING DEVICES

#### MODEL FA-6

- Turn your lift truck into a battery changer
- The fork attachment slides easily onto your lift trucks forks
- 6,000 lbs. capacity
- Swivel hook
- 48" securing chain (to attach around fork carriage)
- Designed for maintenance applications
- For operations with 2 to 5 lift trucks

#### FA Model

Model	Capacity	Weight
FA-6	6,000 lbs.	26 lbs.

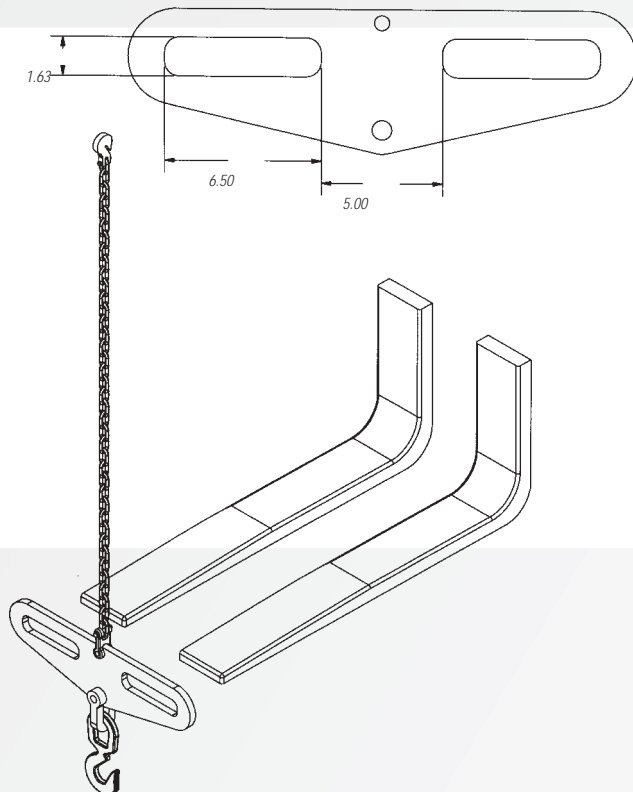
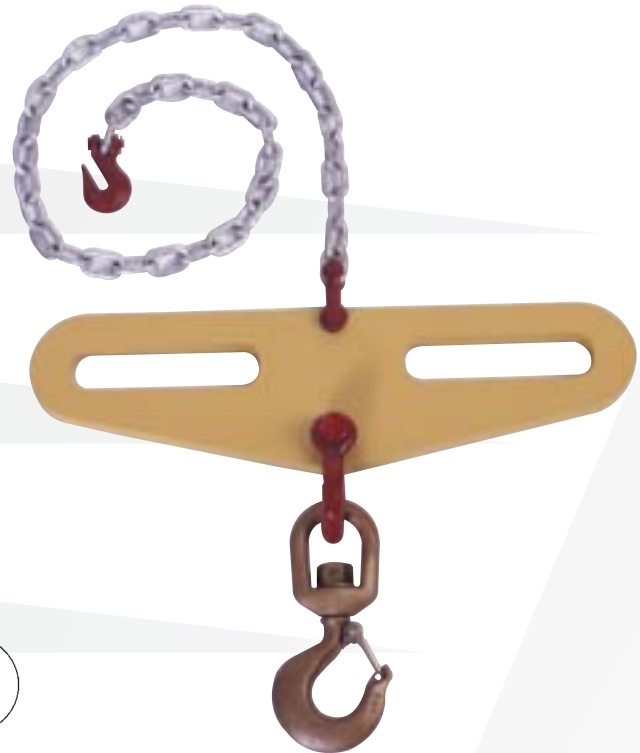

P.O. Box 28990  
St. Louis, MO 63132 USA  
1.800.BHS.9500  
Fax: 314.423.6444  
E-mail: [bhs@bhs1.com](mailto:bhs@bhs1.com)  
Web: [www.bhs1.com](http://www.bhs1.com)

Specifications are subject to change without notice. Copyright ©2002, Battery Handling Systems Inc., St. Louis, MO  
Data Sheet: SF-2401 03/02 15M